

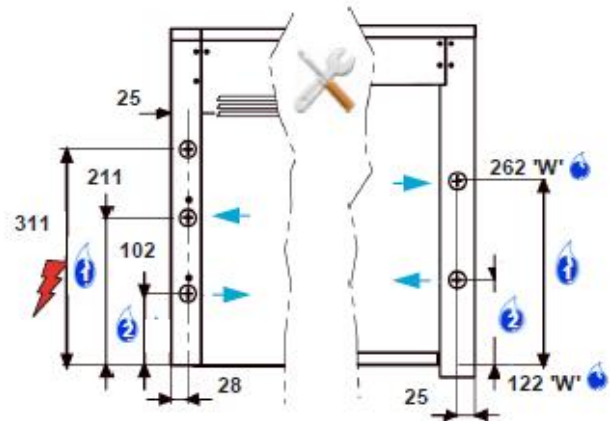

# ASPR 150

FABBRICATORI DI GHIACCIO IN CUBETTI  
 MACHINES À GLAÇON  
 ICE CUBE MACHINE  
 FABRICADORES DE HIELO EN CCUBITOS  
 EISWÜRFELBEREITER

150

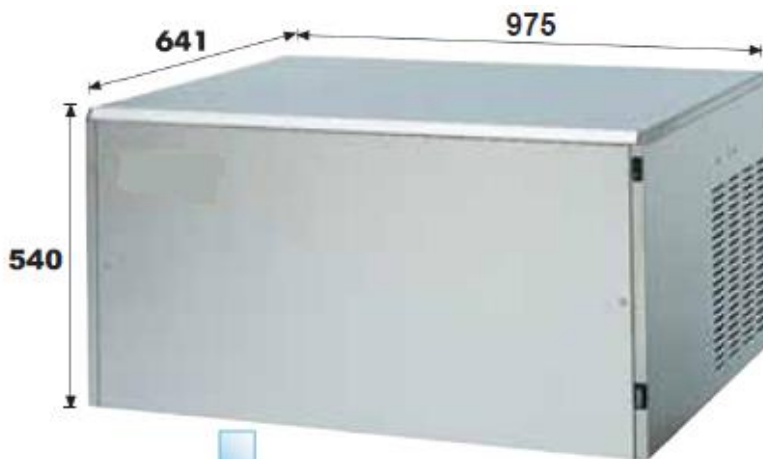

Stainless steel AISI 304

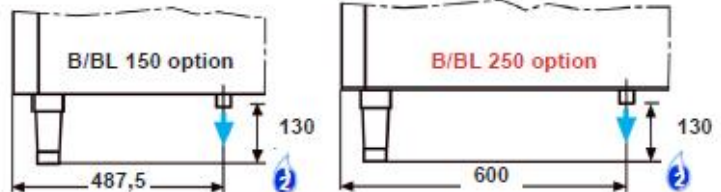
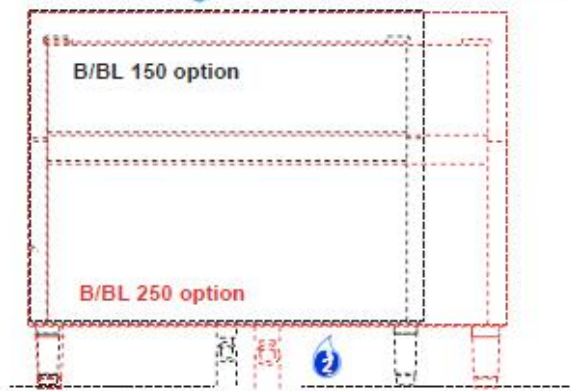

|            |  |  |
|------------|--|--|
| L=1800 mm  |  |  |
| ø 3/4"     |  |  |
| ø 3/4"     |  |  |
| 130÷140 mm |  |  |



**Filter**  
 a richiesta  
 sur demande  
 on request  
 a petición  
 auf Anfrage

a richiesta \* sur demande \* on request  
 a petición \* auf Anfrage

|  |     |     |     |  |
|--|-----|-----|-----|--|
|  |     |     |     |  |
|  | 38° | 87  | 32° |  |
|  | 32° | 109 | 21° |  |
|  | 21° | 142 | 15° |  |
|  | 10° | 150 | 10° |  |

|  |     |     |     |  |
|--|-----|-----|-----|--|
|  |     |     |     |  |
|  | 38° | 107 | 32° |  |
|  | 32° | 122 | 21° |  |
|  | 21° | 137 | 15° |  |
|  | 10° | 152 | 10° |  |



Stainless steel AISI 304



Ø 27 x 32



Air



Water

# ASPR 150

FABBRICATORI DI GHIACCIO IN CUBETTI  
MACHINES À GLAÇON  
ICE CUBE MACHINE  
FABRICADORES DE HIELO EN CCUBITOS  
EISWÜRFELBEREITER

## Dati tecnici – Caractéristiques techniques – Technical specifications – Datos tecnicos – Technische Daten

|   |                |          |
|---|----------------|----------|
| Prod.Kg/24h +10°C - Prod.Lb/24h +10°C                                       |                | 150-330  |
| Prod.Kg/24h +10°C - Prod.Lb/24h +10°C                                       |                | 152-335  |
| Cubetti/Glaçons /cubes/cubitos/Würfel - n° /24h                             |                | 8330     |
| Cubetti/Glaçons /cubes/cubitos/Würfel - n° /24h                             |                | 8440     |
| Contenitore/Bac/Bin/ /Depósito/Behälter <b>OPTION B/BL 150</b>              | Kg/Lb          | 150-330  |
| Contenitore/Bac/Bin/ /Depósito/Behälter <b>OPTION B/BL 250</b>              | Kg/Lb          | 250-550  |
| Dimensione cubetto/Dimensions glaçons/Cubes sizing/Dim. cubitos/Würfelgröße | mm Ø           | 27x32    |
| Larghezza/Largeur/Width/Anchura/Breite                                      | mm             | 975      |
| Profondità/Profondeur/Depth/Profundidad/Tiefe                               | mm             | 641      |
| Altezza/Hauteur/Height/Altura/Höhe  | mm             | 540      |
| Peso netto/Poids net/Net weight/Peso neto/Nettogewicht                      | Kg             | 82       |
| Peso lordo/Poids brut/Gross weight/Peso bruto/Bruttogewicht                 | Kg             | 94       |
| Vol. imballo/Vol.embal/Vol.(packed)/Volumen con embalaje/Verpackungsvolumen | m <sup>3</sup> | 0,53     |
| Alimentazione/Voltage/Voltaje/Anschlusspannung                              | V/Hz/ph        | 230/50/1 |
| Compressore/Compresseur/Compressor/Compresor/Kompressor                     | HP             | 1,7      |
| Compressore/Compresseur/Compressor/Compresor/Kompressor (T evap.= -15°C)    | W              | 1850     |
| Watt - Totale/Total/Total/Total/Gesaint (T = +43°C)                         | W              | 1500     |
| Calorie/Calorie/Calorie/Caloria/Kalorie cond.                               | Kcal/h         | 2420     |
| Ampère - Totale/Total/Total/Total/Gesamt                                    | A              | 8,5      |
| Fusibile/Fusible/Recommanded fuse/Fusible/Netzisierung                      | A              | 20       |
| Refrigerante/Réfrigérant/Cooling gas/Refrigerante/Kühlmittel                | R              | 290      |
| Carica/Charge/Fill/Carga/Füllmenge  | Kg             | 0,149    |
| eq. CO <sub>2</sub>   | Kg             | 0,447    |
| GWP   |                | 3        |
| Carica/Charge/Fill/Carga/Füllmenge  | Kg             | 0,120    |
| eq. CO <sub>2</sub>   | Kg             | 0,360    |
| GWP   |                | 3        |
| Entrata acqua/Entrée eau/Water inlet/Entrada agua/Wasseranschluß            | Ø              | 3/4"     |
| Scarico acqua/Vidange eau/Water outlet/Desague/Wasserabfluß                 | Ø              | 3/4"     |
| Acqua/Eau/Water/Agua/Wasser - lt / h  21°C /  15°C                          |                | 16-52    |
| Pressione acqua/Pression eau/Water pressure/Presión agua/Wasserdruck - bar  | min/max        | 1-6      |
| Temp.ambiente/Temp.ambient/Ambient temp./Temp.ambiente/Rammtemperatur - °C  | min/max        | 10-40    |
| Temp. acqua/Temp. eau/Water temp./Temp. agua/Wassertemperatur - °C          | min/max        | 5-35     |